



Wires / Connecting Parts

Wires

LPWW

A Shape 

B Shape 

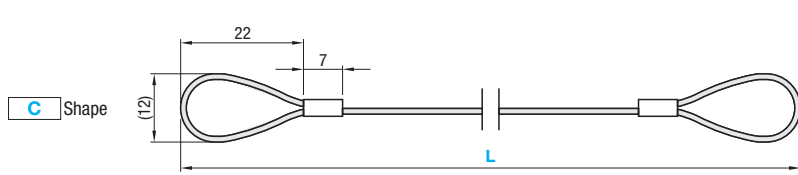
C Shape 

Dimension in () is for reference only. Material: SUS304

Part Number Type	Shape	L 50mm Increment	Allowable Load (Ref.)	Unit Price		
				A	B	C
LPWW	A	100~500	9kg			
	B C	550~1000				

The reference applied load is only a guideline.

Ordering Example

Part Number	L
LPWW C	850

Wires Loop Dia. Configurable

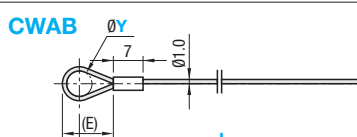
CWAB 

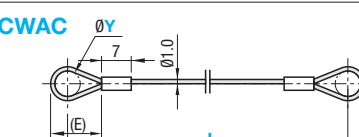
CWAC 

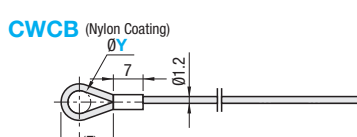
CWCB (Nylon Coating) 

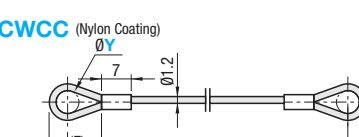
CWCC (Nylon Coating) 

Wire Material: SUS304

Part Number Type	Y Selection	L Configurable	(E)	Allowable Load (Ref.)				Mass (Wire only)				Unit Price			
				CWAB	CWCB	CWAC	CWCC	CWAB	CWCB	CWAC	CWCC	CWAB	CWCB	CWAC	CWCC
CWAB (One Side) CWAC (Both Sides)	10	100~500 (10mm Increment)	20	9kg	5kg	3.97g/m	4.49g/m								
		550~1000 (50mm Increment)													
CWCB (One Side) CWCC (Both Sides)	15	100~500 (10mm Increment)	30	9kg	5kg	3.97g/m	4.49g/m								
		550~1000 (50mm Increment)													
	20	100~500 (10mm Increment)	40	9kg	5kg	3.97g/m	4.49g/m								
		550~1000 (50mm Increment)													

Ordering Example

Part Number	L
CWAB 10	500
CWCC 20	850

Alterations

Part Number	L	DW(TKC)	DW(TKC)
CWAB10	500	DW3	DW5
CWAC15	800	DW5	DW5
CWCC20	850	DW4	TKC

Bracket on Looped Part

Shipped with bracket set on the looped part. One metal joint for CWAB and CWCB and one or two joint(s) for CWAC and CWCC are selectable. Applicable only to CWAB, CWCB, CWAC, CWCC.

Spec.

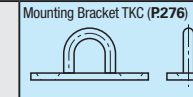
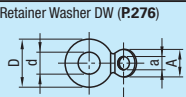
Mounting Bracket TKC (P276)	Retainer Washer DW (P276)
	
Material: SUS304 Accessory: Flat Head Screw M4-5, 2 pcs. (SUS304 Equivalent)	Material: SUS304
Swage TKC with wire threaded.	Swage DW with its Øa part wire threaded.
Code TKC	Code DW

Retainer Washers

DW

Registered Utility Model Registration No.3167276

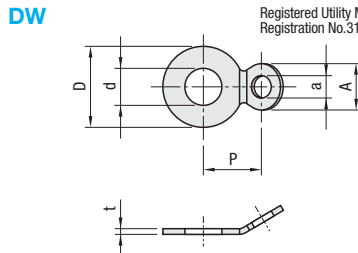

Material: SUS304

Part Number Type	Nominal	d	D	P	a	A	t	Unit Price	Volume Discount Rate	
									1 ~ 9 pc(s)	10 ~ 49 pcs
DW	3	3.2	7	5	2	4	0.5			
	4	4.3	10	6.3	2.5	5	0.8			
	5	5.5	12	8	3	6	1			
	6	6.5	13	9.4	3.5	8	1.5			

For orders larger than indicated quantity, please check with WOS.

Example

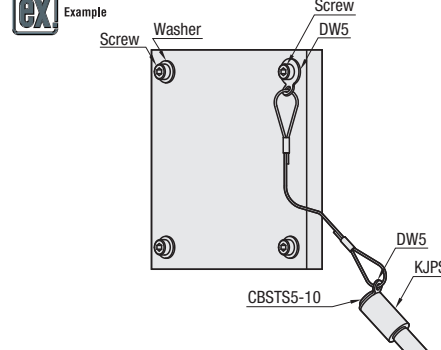

Example: Screw, Washer, DW5, CBST55-10, KJPSHZ

Ordering Example

Part Number	L
DW4	850

Mounting Brackets

TKC

2-M4 Countersink

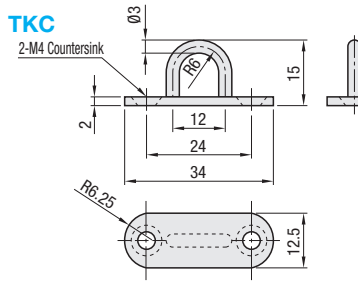

Material: SUS304 Accessory: Flat Head Screw M4-5, 2 pcs. (SUS304 Equivalent)

Part Number	Mass	Applied Load	Unit Price	Volume Discount Rate		
Type	No.	1 ~ 19 pc(s)	20 ~ 49 pcs	50 ~ 99 pcs	100 ~ 200 pcs	
TKC	7g	20kg				

The reference applied load is only a guideline.

Ordering Example

Part Number	L
TKC	850

Crimp Brackets (Package)

PACK-WW

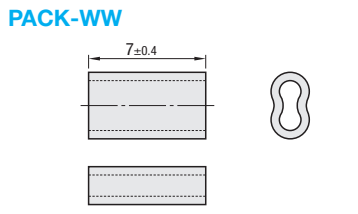

Material: SUS304

Crimping tool for wires (left-hand page).

Part Number	Unit Price	Volume Discount Rate	
Type	No.	1 ~ 2 pkg(s)	3 ~ 4 pkgs. 5 ~ 10 pkgs.
PACK-WW	1		

Available for Nylon Coating Type.

Crimping Tools

WWN



Material Special Alloy Steel (Head) / SS41 (Handle) Hardness 60 ~ 65HRC (Blade) / 40 ~ 45HRC (Clamping Part)

Tool for swaging wires (left-hand page) with crimp bracket (PACK-WW1).

Part Number	Unit Price	Volume Discount Rate	
Type	1 ~ 2 pc(s)	3 ~ 10 pcs.	
WWN			

Attachment for Anchoring Wire

UKC1 **UKC2**

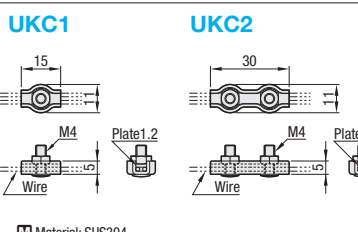

Material: SUS304

Part Number	No.	Mass	Applicable Wire Dia.	Unit Price	Volume Discount Rate	
Type	No.		1 ~ 4 pc(s)	5 ~ 9 pcs	10 ~ 19 pcs	20 ~ 50 pcs
UKC	1	4g	Ø1~1.5			
	2	9g				

Ordering Example

Part Number	L
PACK-WW1	850
UKC1	850