

# Stainless Steel Hinges / Steel Hinges

# Hinges / Hinge Nuts



**SHHPS** (Stainless Steel)  
**SHHPSK** (Stainless Steel, Brushed Finish)  
**SHHPT** (Steel)

Holes on One Side: 2, 3

Dimensions: W, J, S, 4-N, 6-N, L, P, K, 4-CR, D, R

⚠ The hinge nuts on P 1199 are recommended when mating to panels, etc.

Type	Material	Surface Treatment
SHHPS	SUS316	-
SHHPSK	SUS304	Brushed Finish
SHHPT	SPCC or SPHC	Chrome Plating

RoHS10

Part Number	Holes on One Side	* Allowable Load		Mass g	L	W	K	P	J	S	N	T	E	R	CR	D	SHHPS		SHHPSK		
		kg	N														Unit Price	Volume Discount Rate	Unit Price	Volume Discount Rate	
SHHPS SHHPSK	5	2	9	88	43	41	36	8	25	7.5	21	5.5	2	4.6	4.6	7.5	5	1-8 pc(s)	9-100	1-8 pc(s)	9-100
		3	11	108	70	66												58.8	12		
	6	2	12	117	60	48	48	9	30	8	32	6.5	3	5.6	5.6	10	6	1-8 pc(s)	9-100	1-8 pc(s)	9-100
		3	15	147	98	78												68.6	16		
	8	2	25	245	130	59	62	11	37	10	42	6.5	3	6.1	6.1	10	6	1-8 pc(s)	9-100	1-8 pc(s)	9-100
		3	38	372	230	96												127.4	25		
	845	2	30	294	190	70	80	13.5	43	16.5	47	6.5	3	6.1	6.1	10	6	1-8 pc(s)	9-100	1-8 pc(s)	9-100
		3	40	392	325	113												174	46		

\* The allowable load is the value when 2 pieces are used.

Part Number	Holes on One Side	* Allowable Load		Mass g	L	W	K	P	J	S	N	T	E	R	CR	D	SHHPT			
		kg	N														Unit Price	Volume Discount Rate		
SHHPT	5	2	9	88	36	41	36	8	25	7.5	21	5.5	2	4.6	4.6	4	5	1-8 pc(s)	9-100	
		3	11	108	59	66												58.8	16	
	6	2	12	117	50	48	48	9	30	8	32	6.5	3	6.5	6.5	5	6	1-8 pc(s)	9-100	
		3	15	147	83	78												68.6	16	
	8	2	25	245	124	59	62	11	37	10	42	6.5	3	3.2	6.5	6.5	5	6	1-8 pc(s)	9-100
		3	38	372	207	96													107.8	39
	845	2	30	294	181	70	80	13.5	43	16.5	47	6.5	3	3.2	6.5	6.5	5	6	1-8 pc(s)	9-100
		3	40	392	298	113													127.4	47

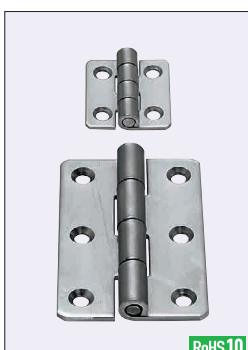

**SHHPSD** (Stainless Steel, Countersink)

Holes on One Side: 2, 3

Dimensions: W, J, S, 4-N, 6-N, L, P, K, 4-CR, D, R

⚠ The allowable load is the value when 2 pieces are used.

Material: SUS304

Part Number	Holes on One Side	* Allowable Load		Mass g	L	W	K	P	J	S	N		T	E	R	CR	D	SHHPSD		
		kg	N								Through	Countersink						Unit Price	Volume Discount Rate	
SHHPSD	5	2	9	88	34	41	36	8	25	7.5	21	5.5	8.6	2	4.6	4.6	4	5	1-8 pc(s)	9-100
		3	11	108	56	66													58.8	16
	6	2	12	117	49	48	48	9	30	8	32	6.5	10.6	3	6.1	6.1	5	6	1-8 pc(s)	9-100
		3	15	147	80	78													68.6	16
	8	2	25	245	111	59	62	11	37	10	42	6.5	10.6	3	6.1	6.1	5	6	1-8 pc(s)	9-100
		3	38	372	185	96													107.8	39
	845	2	30	294	162	70	80	13.5	43	16.5	47	6.5	10.6	3	6.1	6.1	5	6	1-8 pc(s)	9-100
		3	40	392	266	113													127.4	47

\* The allowable load is the value when 2 pieces are used.

Ordering Example	Part Number	Holes on One Side
	SHHPS6	2
	SHHPSD6	3



**Flat Hinges**

**HHS**

ShapeNo. A, B, C

Dimensions: W, W1, W2, L1, L2, L3, C, C1, t, d, Division

Material: SUS304

Part Number	Type	No.	L	Shape No.	W	W1	W2	L1	L2	L3	C	C1	t	d	Division	* Allowable Load (N)	Weight (g)	Unit Price		Volume Discount Rate	
																		1-19 pc(s)	20-99	100	
HHS	A	25	25	30	20	12	-	16	-	-	2	3.8	0.8	3.4	3	9.8	6				
		30	22					58.8								12					
		40	22					68.6								16					
		50	22					127.4								25					
		65A	30					23								23	4.5	5	147	46	
		75A	30					27								27					
	B	65	65	50	36	30	22	22	4	8.5	2	6	12.7	3	6.6	294	100				
		75	75	30	26	26															
	C	90A	90	60	38	-	35	35	6	12.7	3	6.6	26	26	26	5	6	6			
		100A	100	46	36	34	34														
		100	100	48	36	26	26	26													
		100	100	48	36	26	26	26													

\* The allowable load is the value when 2 pieces are used.

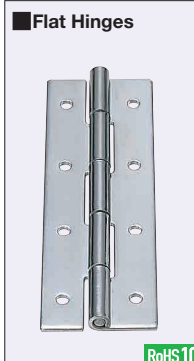

**Flat Hinges**

**HHKS**

ShapeNo. A, B, C

Dimensions: 32, 20, 03.4, L1, L2, L3, 06.3, 03, 1.5

Material: SUS304

Part Number	Type	L	Shape No.	ℓ	L1	L2	L3	Division	* Allowable Load (N)	Weight (g)	Unit Price		Volume Discount Rate	
											1-19 pc(s)	20-99	100	
HHKS	A	25	30	6	13	-	-	3	29.4	13				
		30		7	16	-	-		39.2	16				
		40		8	24	-	-		58.8	21				
		50		10	30	-	-		68.6	26				
		65		8.5	24	24	-		98.0	34				
		75		9.5	28	28	-		107.8	39				
	B	90	10	35	35	-	127.4	47						
		100	11	26	26	26	147.0	52						

\* The allowable load is the value when 2 pieces are used.



**Hinge Nuts**

**HHST  
HHKST**

Number of Holes: 2, 3, 4

Dimensions: B, A, P, M

Material: SUS304

Part Number	Type	No.	Number of Holes	B	A	P	M	Applicable Hinge	Unit Price		Volume Discount Rate		Example
									1-9 pc(s)	10-100	10-100		
HHST	2	25	6	22	16	3		HHS25				ex Example Hinge Nuts	
		30	6	28	22	3		HHS30					
		40	7	36	28	3		HHS40					
		50	7	45	36	4		HHS50					
		65	9	55	23	4		HHS65A					
		75	11	65	27	5		HHS75A					
HHKST	2	25	12	82	35	6		HHK25					
		30	12	90	26	6		HHK30					
		40	6	32	24	3		HHK40					
		50	6	39	30	3		HHK50					
		65	6	57	24	3		HHK65					
		75	6	65	28	3		HHK75					
HHST	3	25	6	79	35	3		HHST25					
		30	6	87	26	3		HHST30					
		40	6	87	26	3		HHST40					
		50	6	87	26	3		HHST50					

Ordering Example	Part Number
	HHST100
	HHKS100
	HHST30
	HHKST75

