

Height Adjusting Blocks for Miniature Linear Guides

Standard Rail Type

Note that, for some of the types shown here, order might be unable to be received by the MISUMI Malaysia, Indonesia and/or India offices.

Linear Guide Stopper Bolts / Linear Guide Block Stopper Plates

Rail Mounting Hole Caps / Rail Push Plates

Blocks for Miniature Linear Guides. Width/Height tolerance and parallelism are guaranteed.

Type		Material	Surface Treatment
Datum Side	Free Side		
GETA	GETE	S45C Equivalent	Electroless Nickel Plating
AGETA	AGETE	Aluminum Alloy	Clear Anodize

RoHS 10

Part Number	Type	(Slide Guide H Dimension) No.	L Selection								1mm Increment	S										
			40	55	70	85	100	115	130	135		155	175	195	Through + Counterbored Hole	d	G	h				
GETA AGETA GETE AGETE		8	40	55	70	85	100	115	130	10-60	7	2	1	5	15	12.5	15	M2	3.5	6	3.5	
		10	55	75	95	115	135	155	175		195	9	3	1.5	7.5	20	17.5	20	M3	4.5	8	4.5
		13	70	95	120	145	170	195	220		245	12	3	2	10	25	22.5	25	M3	4.5	8	4.5
		16	110	150	190	230	270	310	350		390	15	3	3	15	40	35	40	M3	5.5	9.5	5.5
		20	160	220	280	340	400	460				20	3	4	20	60	50	60	M5	6.5	11	6.5

When T ≤ Mx4, the pilot holes for tapping go through.

Ordering Example: Part Number - L - T

Example: **GETA10 - 115 - 20**

Price List

No.	L	Unit Price			
		GETA	AGETA	GETE	AGETE
40					
55					
70					
85					
100					
115					
130					
135					
155					
175					
195					
215					
235					
255					
275					
70					
95					
120					
145					
170					
195					
220					
245					
270					
295					
320					
345					
370					
395					
110					
150					
190					
230					
270					
310					
350					
390					
430					
470					
160					
220					
280					
340					
400					
460					

Number of Holes

No.	L	Number of Holes	
		M	S
40		3	2
55		4	3
70		5	4
85		6	5
100		7	6
115		8	7
130		9	8
135		9	8
155		10	9
175		11	10
195		12	11
215		13	12
235		14	13
255		14	13
275		14	13
70		3	2
95		4	3
120		5	4
145		6	5
170		7	6
195		8	7
220		9	8
245		10	9
270		11	10
295		12	11
320		13	12
345		14	13
370		15	14
395		16	15
110		3	2
150		4	3
190		5	4
230		6	5
270		7	6
310		8	7
350		9	8
390		10	9
430		11	10
470		12	11
160		3	2
220		4	3
280		5	4
340		6	5
400		7	6
460		8	7

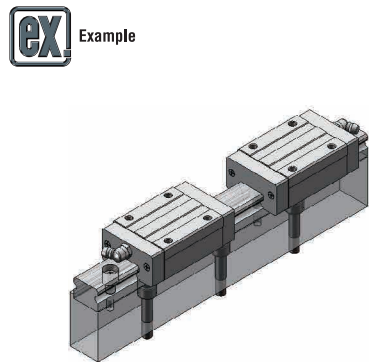

Applicable Linear Guides

P533-P554 Compatible with Miniature Linear Guides L Selectable Types.

- H13 is not applicable to L420 or more.
- H16 is not applicable to L510 or more.
- H20 is not applicable to L520 or more.

Linear Guide Stopper Bolts

Type	Material	Surface Treatment
SBLT	SUS303	
SBLTJ	Knurled Head Urethane (Store A80)	Threaded Section SUS304

* SBLTJ is a hex socket set screw with a heat bonded urethane head.

Part Number	Type	M (Coarse)	L	A	D	B		t		Unit Price	Volume Discount Rate	Unit Price	Volume Discount Rate	
						SBLT	SBLTJ	SBLT	SBLTJ					
SBLT SBLTJ		3	8	10	12	6	8	10	5.5	2.5	1.5	3	2	1 - 9 pc(s), 10 - 30 pcs.
		4	10	8	7	3	2	3.5	2.5					
		5	16	18	8.5	4	2.5	4	3					
		6	18	20	10	5	3	5	3.5					

For orders larger than indicated quantity, please request a quotation.

Linear Guide Block Stopper Plates

RoHS 10

Material: SUS304D

Part Number	Type	No.	A	B	C	ℓ	Unit Price	Volume Discount Rate
SVP		24	19	12	14	4.5		
		28	26	15	19	6		
		33	29	19	22	7		

For orders larger than indicated quantity, please request a quotation.

Rail Mounting Hole Caps (Package)

PACK-SGLC

Material: Polyacetal (Black)

Part Number	Type	M (Applicable Screw Hole)	D	P	T (d)	Qty. per Pkg.	Unit Price
PACK-SGLC		3	5.8	6.2	1.5	4.2	100 pcs./pkg.
		5	9.3	9.7	3	7.3	100 pcs./pkg.
		6	10.8	11.2	3	8.8	100 pcs./pkg.

For orders larger than indicated quantity, please request a quotation.

Rail Push Plates

RoHS 10

Type	Part	Material	Surface Treatment
SGU	① Main body	S45C	Electroless Nickel Plating
	② Screw	SUS304	

Part Number	Type	H	L Selection	Tapped Hole M	Included Screw Size	Unit Price	Volume Discount Rate
SGU	5		40	3	M3-12		
			100		M3-12		
			340		M3-12		
	6		40	4	M4-12		
			100		M4-12		
			340		M4-12		

For orders larger than indicated quantity, please request a quotation.

Ordering Example: Part Number - L - A

Example: **SBLT3 - 10 - 8**

Example: **SVP24 - 10 - 8**

Example: **PACK-SGLC3 - 100**