

Urethane Cam Followers

Straight Slot

■Features: Urethane is baked on the outer rings of the cam followers.



RoHS10

Type		Material		Accessory
With Seal	No Seal	Urethane	Cam Followers	
CFFRRZ	CFFRR	Shore A90	SUJ2	1 Hex Nut (S45C Carbon Steel, Black Oxide)
CFFRRZS	CFFRRS		SUS440C Equivalent	Hex Nut 1 pc. (SUS304)

(With Seal)

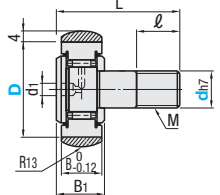

(No Seal)

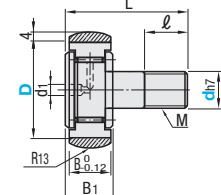

⚠ Operating Temp.: 80°C or lower
⚠ Grease hole is provided on the head only.

Part Number	Type	D Selectable	MxPitch	B	B ₁	L	d ₁	ℓ	Max. Allowable Load (N)	Allowable Rotational Speed (rpm)	Mass (g)	Unit Price			
												CFFRRZ	CFFRRZS	CFFRR	CFFRRS
(With Seal)	5	13	5x0.8	9	10	23	3.1	7.5	68	1500	13				
CFFRRZ	6	16	6x1.0			28		9	90	1300	22				
CFFRRZS	8	19	8x1.25	11	12	32	4	11	96	1180	33				
(No Seal)	10	22	10x1.25	12	13	36		13	110	1060	50				
CFFRR		26							118	930	66				
CFFRRS															

⚠ The standards of d12, 16 have been modified to those with the hex socket on the head and thread. For the new part number, see P.1052.



RoHS10

Type		Material		Accessory
With Seal	No Seal	Urethane	Cam Followers	
CFFRUZ	CFFRU	Shore A90	SUJ2	1 Hex Nut (S45C Carbon Steel, Black Oxide)
CFFRUZS	-		SUS440C Equivalent	Hex Nut 1 pc. (SUS304)

(With Seal)

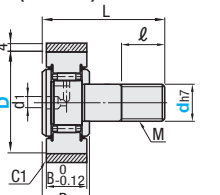

(No Seal)

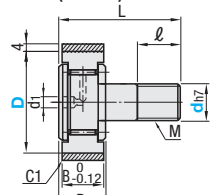

⚠ Operating Temp.: 80°C or lower
⚠ Grease hole is provided on the head only.

Part Number	Type	D Selectable	MxPitch	B	B ₁	L	d ₁	ℓ	Max. Allowable Load (N)	Allowable Rotational Speed (rpm)	Mass (g)	Unit Price		
												CFFRUZ	CFFRUZS	CFFRU
(With Seal)	5	13	5x0.8	9	10	23	3.1	7.5	68	1500	13			
CFFRUZ	6	16	6x1.0			28		9	90	1300	22			
CFFRUZS	8	19	8x1.25	11	12	32	4	11	96	1180	33			
(No Seal)	10	22	10x1.25	12	13	36		13	110	1060	50			
CFFRU		26							118	930	66			

⚠ The standards of d12, 16 have been modified to those with the hex socket on the head and thread. For the new part number, see P.1052.

Ordering Example: Part Number - D
CFFRUZ10 - 22

[Material Properties]		
Item	Urethane	MC Nylon
Allowable Load	△	○
Abrasion Resistance	○	△
Mechanical Strength	○	◎
Heat Resistance	×	△
Chemical Resistance	×	○

⚠ For MC Nylon, see P.1049.

Urethane Cam Followers

With Hex Socket

■Features: Urethane is baked on the outer rings of the cam followers.



RoHS10

Type				Material		Accessory
Hex Socket on Head (d5 ~ 10)		Hex Socket on Head and Thread (d12 ~ 16)		Urethane	Cam Followers	
With Seal	No Seal	With Seal	No Seal			
CFFRAZ	CFFRA	CFFRAH	CFFRTH	Shore A90	SUJ2	1 Hex Nut (S45C Carbon Steel, Black Oxide)
CFFRAS	-	CFFRAH	CFFRTH		SUS440C Equivalent	Hex Nut 1 pc. (SUS304)
-	-	-	-	Shore A50	SUJ2	1 Hex Nut (S45C Carbon Steel, Black Oxide)

Hex Socket on Head (d5 ~ 10) (With Seal)

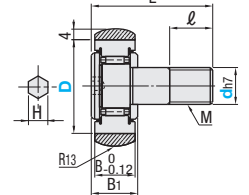

(No Seal)



Hex Socket on Head and Thread (d12 ~ 16) (With Seal)

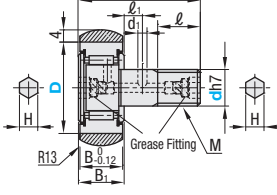

(No Seal)



⚠ Operating Temp.: 80°C or lower
⚠ For d10 and smaller sizes, no grease replenishing hole is provided.

Part Number	Type	D Selectable	MxPitch	B	B ₁	L	d ₁	ℓ	ℓ ₁	H	Allowable Load (N)	Allowable Rotational Speed (rpm)		Mass (g)	Unit Price						
												Shore A90	Shore A50		CFFRA	CFFRAS	CFFRAH	CFFRTH	CFFRAH	CFFRTH	CFFRSH
(With Seal)	5	13	5x0.8	9	10	23	3.1	7.5		3	68	1500	250	13							
CFFRAZ	6	16	6x1.0			28		9			90	1300	220	22							
CFFRAS	8	19	8x1.25	11	12	32	4	11		4	96	1180	190	33							
(No Seal)	10	22	10x1.25	12	13	36		13		5	110	1060	170	50							
CFFRAU		26									118	930	150	66							
(With Seal)	12	30	12x1.5	14	15	40	6	14	6	6	147	830	140	103							
CFFRAH		32									151	800	130	113							
CFFRSH	16	35	16x1.5	18	19.5	52	18	18	8		202	740	120	181							
CFFRTH																					
CFFRSH																					
CFFRTH																					

⚠ The standards of d12, 16 have been modified to those with the hex socket on the head and thread.



RoHS10

Type				Material		Accessory
Hex Socket on Head (d5 ~ 10)		Hex Socket on Head and Thread (d12 ~ 16)		Urethane	Cam Followers	
With Seal	No Seal	With Seal	No Seal			
CFFRUA	CFFRUU	CFFRAH	CFFRTH	Shore A90	SUJ2	1 Hex Nut (S45C Carbon Steel, Black Oxide)
CFFRUAS	-	CFFRSH	-		SUS440C Equivalent	Hex Nut 1 pc. (SUS304)
CFFRUAG	-	CFFRSH	-	Shore A50	SUJ2	1 Hex Nut (S45C Carbon Steel, Black Oxide)

Hex Socket on Head (d5 ~ 10) (With Seal)

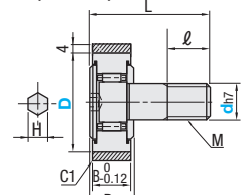

(No Seal)



Hex Socket on Head and Thread (d12 ~ 16) (With Seal)

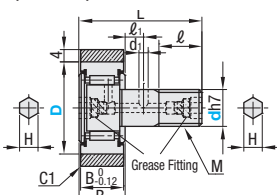

(No Seal)



⚠ Operating Temp.: 80°C or lower
⚠ For d10 and smaller sizes, no grease replenishing hole is provided.

Part Number	Type	D Selectable	MxPitch	B	B ₁	L	d ₁	d ₂	ℓ	ℓ ₁	H	Allowable Load (N)	Allowable Rotational Speed (rpm)		Mass (g)	Unit Price					
													Shore A90	Shore A50		CFFRU	CFFRUAS	CFFRUAG	CFFRUU	CFFRAH	CFFRTH
(With Seal)	5	13	5x0.8	9	10	23	3.1	7.5		3	68	1500	250	13							
CFFRUA	6	16	6x1.0			28		9			90	1300	220	22							
CFFRUAS	8	19	8x1.25	11	12	32	4	11		4	96	1180	190	33							
CFFRUAG	10	22	10x1.25	12	13	36		13		5	110	1060	170	50							
CFFRUU		26									118	930	150	66							
(With Seal)	12	30	12x1.5	14	15	40	6	14	6	6	147	830	140	103							
CFFRAH		32									151	800	130	113							
CFFRSH	16	35	16x1.5	18	19.5	52	18	18	8		202	740	120	181							
CFFRTH																					

⚠ The standards of d12, 16 have been modified to those with the hex socket on the head and thread.

Part Number Substitution Table for Cam Follower Standard Changes (d12, 16)			
Type	Old Part Number (d12, 16)		New Part Number (d12, 16)
	Old Standard	Old Hex Socket	Hex Socket on Head and Thread
Urethane	CFFRRZ	CFFRA	CFFRAH
	CFFRRZS	CFFRAS	CFFRSH
	CFFRR	CFFRU	CFFRTH
	CFFRRS	-	CFFRTH
	CFFRRS	-	CFFRTH
	CFFRUZ	CFFRU	CFFRAH
	CFFRUZS	CFFRUAS	CFFRSH
	-	CFFRUAG	CFFRSH
	CFFRU	CFFRUU	CFFRTH
	CFFRU	CFFRUU	CFFRTH

Ordering Example: Part Number - D
CFFRAH12 - 30