

Steel Plate Ball Bearing Units / Shaft End Caps

Flanged

■ **Features:** Inexpensive Ball Bearing Units with pressed sheet metal housing.

Steel Plate Ball Bearing Units - Flanged



RoHS 10

HBTP

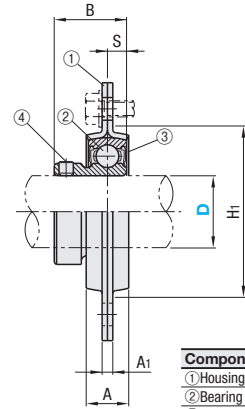
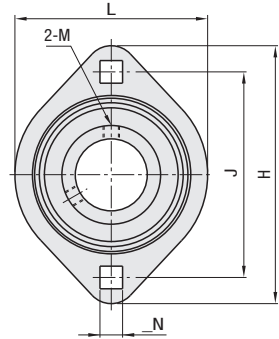

Accuracy: JIS B 1558
JIS B 1514
JIS B 1559
Operating Temperature: -15 ~ +100°C

Component	Material	Surface Treatment
① Housing	SPCC	Black Oxide
② Bearing	SUJ2	-
③ Rubber Seal	Nitrile Rubber (NBR)	-
④ Set Screw	SCM435	-

Ⓜ Bearing and sheet metal are shipped unassembled. Assemble before use.
Ⓜ An angle of 2-M (set screw) is 120°.

Part Number	Type	D	L	H	A	J	N	A ₁	H ₁ Min.	B	S	Mounting Screw Nominal	Allowable Load (N)		Bearing Basic Load Rating (N)		Set Screw			Mass (g)	Unit Price
													Radial	Axial	Cr (Dynamic)	Co (Static)	M	Tightening Torque (N·cm)	Axial Load Capacity (N)		
HBTP	12	59	81	14	63.5	7	4	49	22	6	M6	2650	640	9550	4800	M5x0.8	240	478	250	kgf=Nx0.101972	
	15	59	81	14	63.5	7	4	49	22	6	M6	2650	640	9550	4800		240	478	240		
	20	67	90	16	71.5	9	4	56	24.7	7	M8	3100	740	12800	6600	250	1280	290			
	25	71	95	18	76	9	4	60	27	7.5	M8	3530	900	14000	7900	490	1400	360			
	30	84	113	18	90.5	11	5.2	71	30.3	8	M10	4900	1220	19600	11300	490	1960	560			

Ordering Example Part Number **HBTP12**

EX Example

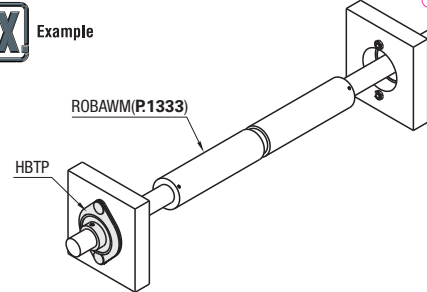

Steel Plate Ball Bearing Units

Pillow Blocks

■ **Features:** Inexpensive Pillow Block Ball Bearing Units with sheet metal housing.



RoHS 10

PBTP

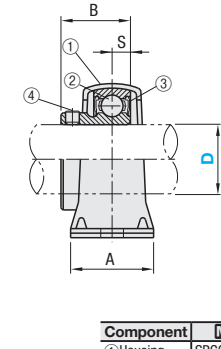
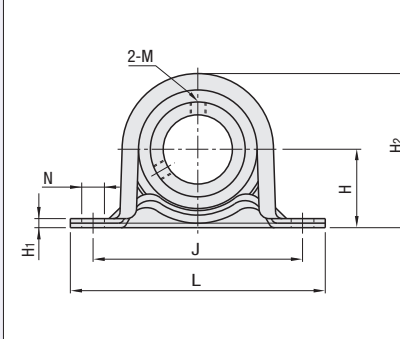

Accuracy: JIS B 1558
JIS B 1514
JIS B 1559
Operating Temperature: -15 ~ +100°C

Component	Material	Surface Treatment
① Housing	SPCC	Black Oxide
② Bearing	SUJ2	-
③ Rubber Seal	Nitrile Rubber (NBR)	-
④ Set Screw	SCM435	-

Ⓜ Bearing and sheet metal are shipped unassembled. Assemble before use.
Ⓜ An angle of 2-M (set screw) is 120°.

Part Number	Type	D	L	H	A	J	N	H ₁	H ₂	B	S	Mounting Screw Nominal	Allowable Load (N)		Bearing Basic Load Rating (N)		Set Screw			Mass (g)	Unit Price
													Radial	Axial	Cr (Dynamic)	Co (Static)	M	Tightening Torque (N·cm)	Axial Load Capacity (N)		
PBTP	12	86	22.2	25	68	9.5	3.2	44	22	6	M8	2150	830	9550	4800	M5x0.8	240	478	160	kgf=Nx0.101972	
	15	86	22.2	25	68	9.5	3.2	44	22	6	M8	2150	830	9550	4800		240	478	150		
	20	98	25.4	32	76	9.5	3.2	50	24.7	7	M8	2650	1030	12800	6600	250	1280	210			
	25	108	28.6	32	86	11.5	4	56	27	7.5	M10	3700	1470	14000	7900	490	1400	290			
	30	117	33.3	38	95	11.5	4	66	30.3	8	M10	4400	1670	19600	11300	490	1960	420			

Ordering Example Part Number **PBTP12**

EX Example

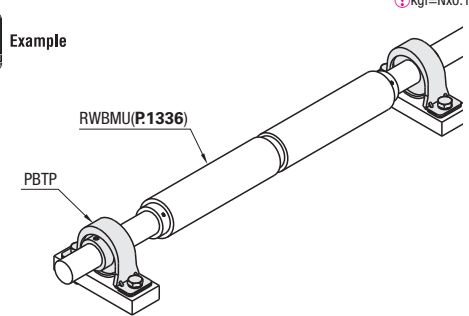

Shaft End Caps



RoHS 10

EDCB EDCM EDCS

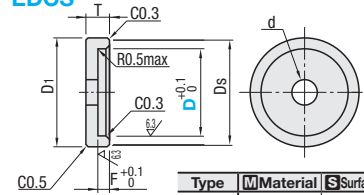

Type	Material	Surface Treatment
EDCB	S45C	Black Oxide
EDCM	Equivalent	Electroless Nickel Plating
EDCS	SUS304 Equivalent	-

Part Number	Type	D	D ₁	D _s	T	F	d	Unit Price		
								EDCB	EDCM	EDCS
EDCB EDCM EDCS	10	14	13.4				4.5			
	12	16	15.4	5	2					
	15	19	18.4				5.5			
	17	21	20.4							
	20	26	25.4	7	3		6.6			
	25	31	30.4							
	30	37	36.4	8			9			
	35	42	41.4					11		
	40	47	46.4	10	4		14			

Ordering Example Part Number **EDCB20**

EX Example

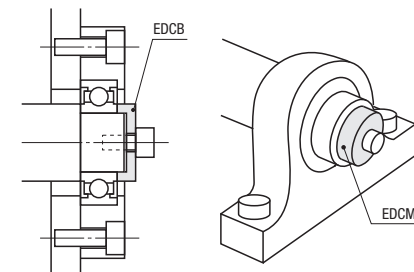

Mounting Steps

1. Insert the shaft into the bearing and locate it to the predetermined position.
2. Install sheet metal housings (2 sheet metal) and secure them with screws. (The bearing is fixed after the assembly)
3. Align the shaft and secure with a set screw.

